

N°12: Behra-Gurney
sur 0774 aux 24 Heures
du Mans 1959

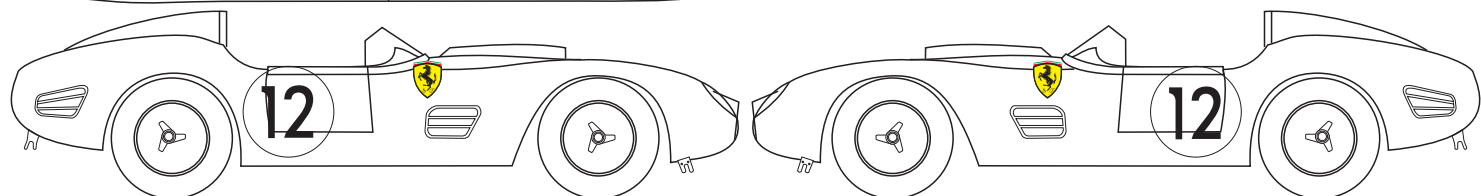

Pièces résine:

- 1 coque *Rouge Rosso Corsa*
- 1 châssis *noir satiné, habitacle aluminium*
- 1 partie arrière-dessous de coque *Rosso Corsa*
- 2 sièges *noir satiné*
- 1 appuie-tête *noir satiné*
- 1 rétroviseur *rouge*

White Metal:

- 2 pots d'échappement (G & D)
- 1 bouchon de réservoir

Pièces tournées:

- 12 trompettes d'admission
- 4 tromblons d'échappement
- 1 moyeu de volant
- 2 feux arrières
- 3 feux de plaque
- 2 phares
- 2 phares longue portée
- 1 levier de vitesse

Divers:

- 2 roues fil avants
- 2 roues fil arrières
- 2 pneus avants
- 2 pneus arrières
- 2 demi-volants plastiques
- 2 axes 1.5mm
- 2 vis
- 2 plexis de phares thermoformés
- 1 pare-brise thermoformé
- 1 prise d'air de capot thermoformée
- 1 décal
- 1 planche de photodécoupe nickelée
- 1 planche de photodécoupe acier

Resin parts:

- 1 body *red Rosso Corsa*
- 1 chassis *satin black, cockpit=Silver*
- 1 underside rear part of body *red*
- 2 seats *satin black*
- 1 headrest *satin black*
- 1 mirror *red*

White metal

- 2 exhaust pipes (RH & LH)
- 1 fuel cap

Machined parts:

- 12 trumpets
- 4 exhausts
- 1 steering wheel hub
- 2 rear lights
- 1 id. light
- 2 headlights
- 2 spotlights
- 1 gear stick

And...

- 2 front wired wheels
- 2 rear wired wheels
- 2 front tyres
- 2 rear tyres
- 2 plastic half-rims of steering wheel
- 2 axes 1.5mm
- 2 screws
- 2 vacformed headlights covers
- 1 vacformed windscreen
- 1 vacformed bonnet scoop
- 1 decal
- 1 sheet of plated p/e parts
- 1 sheet of steel p/e part

Photodécoupes:

- P1= cloison arrière / rear bulkhead
- P2(x2)= lève-vites avants *rouge* / front quick liftjacks points *red*
- P3(x2)= non utilisé ici / no use for this model
- P4(x2)= lève-vites arrières *rouge* / rear quick liftjacks points *red*
- P5= volant / steering wheel
- P6= intérieur de porte gauche *noir satiné* / LH door inner *satin black*
- P7= déflecteur d'admission / trumpets deflector
- P8= intérieur de porte droite *noir satiné* / RH door inner *satin black*
- P9= trappe d'aération habitacle *rouge* / cockpit air intake plate *red*
- P10(2G+2D)= papillons de roue / wheels nuts
- P11(4x2)= attaches-capot *cuir* / bonnet fasteners *leather*
- P12(x4)= disques de frein *étrier acier* / disc brakes *caliper: steel*
- P13(x2)= grilles d'ailes arrières / rear fenders grilles
- P14= cloison gauche de cockpit / cockpit LH side
- P15(x2)= grilles d'ailes avants / front fenders grilles
- P16= entouragement de prise d'air capot *rouge* / Scoop surround *red*
- P17= plaque de carbus / trumpets plate
- P18= entouragement de pare-brise *rouge* / windscreen surround *red*
- P19= tableau de bord / dashboard
- P20(x2)= bavettes *rouge* / mudguards *red*
- P21= non utilisé ici / no use for this model
- P22= pare-moustiques *rouge* / fly screen *red*
- P23= repose-pieds / footrest
- P24(x2)= pédales d'embrayage et frein / clutch & brake pedals
- P25= pédale d'accélérateur *bois* / throttle pedal *wooden*
- P26= cloison droite de cockpit / cockpit RH side
- P27= grille de vitesses / gear grille
- P28= glace de rétroviseur / mirror glass
- P29(x2)(Sebring)= Ecusson Pinin Farina / P. F. Badge
- S1= essuie-glace / wiper
- S2= grille de calandre / front grille
- S3= non utilisé ici / no use for this model
- S4(x2)= charnières de portes / doors hinges
- S5= support central interne de pare-brise / inside central screen frame
- S6(x2)= supports latéraux de pare-brise / side screen frames
- S7(x10+2)= attaches de capote / hood fasteners
- S8= grille d'entrée d'air / scoop grille
- S9(x2)= supports d'échappement / exhausts hangers
- S10= support extérieur de pare-brise / outside central screen frame
- S11(x2+1)= poignées de trappes eau-huile / oil-water fillers handles
- S12(x2+1)= attaches-capots / fasteners

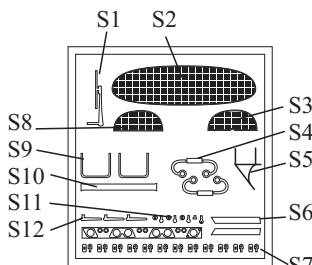
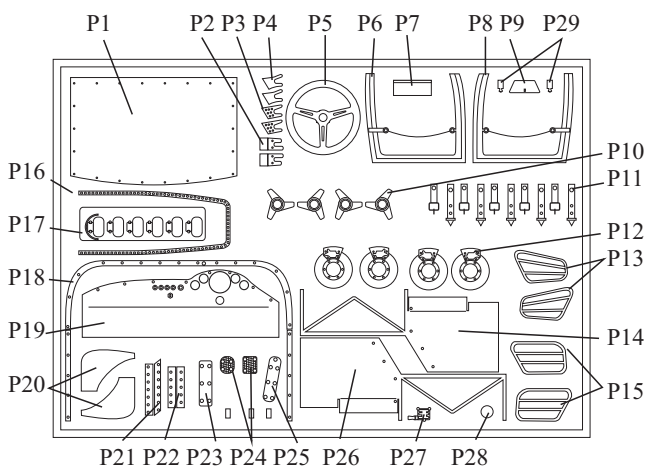

Des problèmes? Des suggestions? N'hésitez pas:
Contactez-nous!
Any Problem? Suggestion? Please, contact us:

RENAISSANCE



BP108
79 rue Henri Dillies 59155 FACHES THUMESNIL
FRANCE
Tel: (33) 03 20 53 82 97. Fax(33) 03 20 85 98 37

Avant peinture:

Collez et mastiquez la partie inférieure de l'arrière. Collez les entourages de pare-brise et de prise d'air P18 et P16, les bavettes P20, la trappe P9 (en position ouverte?), les lève-vitres P2/P4.

Percages:

0.3mm pour les attaches-capot S12, les attaches de capote S7, les fermoirs de trappes S11.

0.6mm pour les feux de plaque, le levier de vitesse, les emplacements des cloisons P14/26.

1mm pour le moyeu de volant et les feux arrière.

1.5mm pour les puits de vis et les échappements.

Before Painting:

Glue the rear part under body, and fill around carefully with putty. Glue P16 & P18, also mudguards P20, P9 (open?) and P2/P4.

Drilling:

0.3mm for fasteners S12, S7, S11.

0.6mm for id. lights, gear stick, locations of P14/26.

1mm for steering wheel hub and rear lights

1.5mm for screws and exhausts pipes

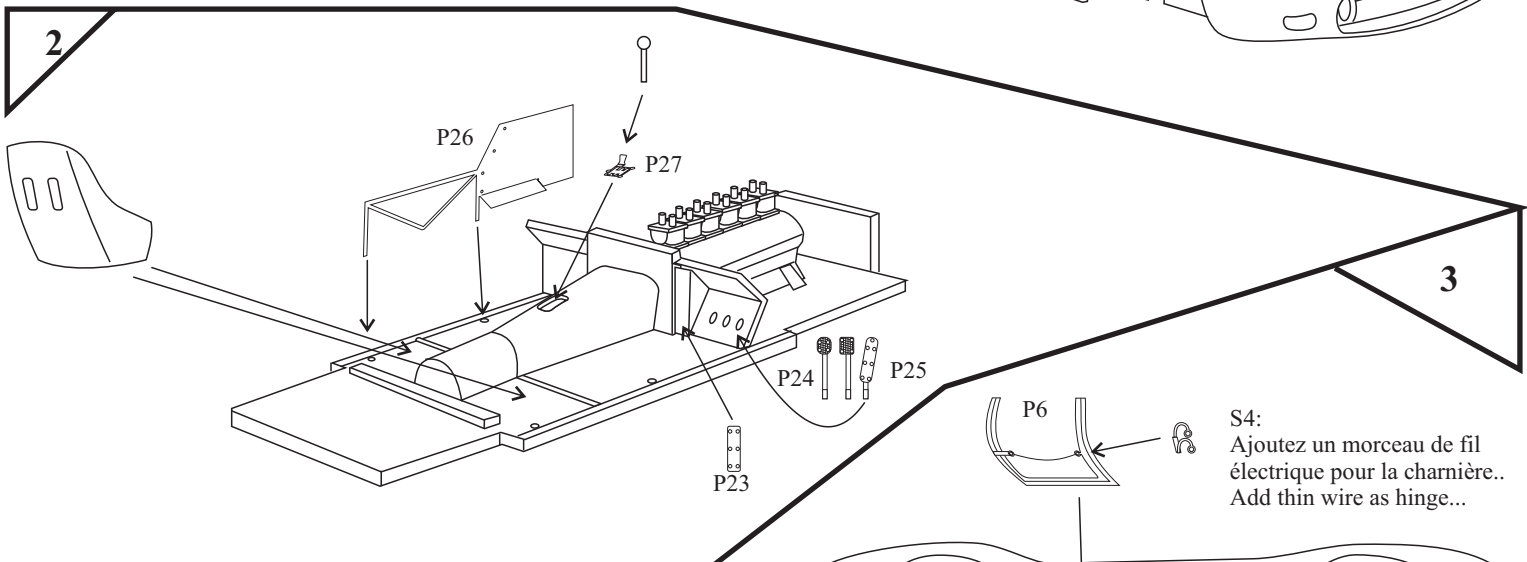
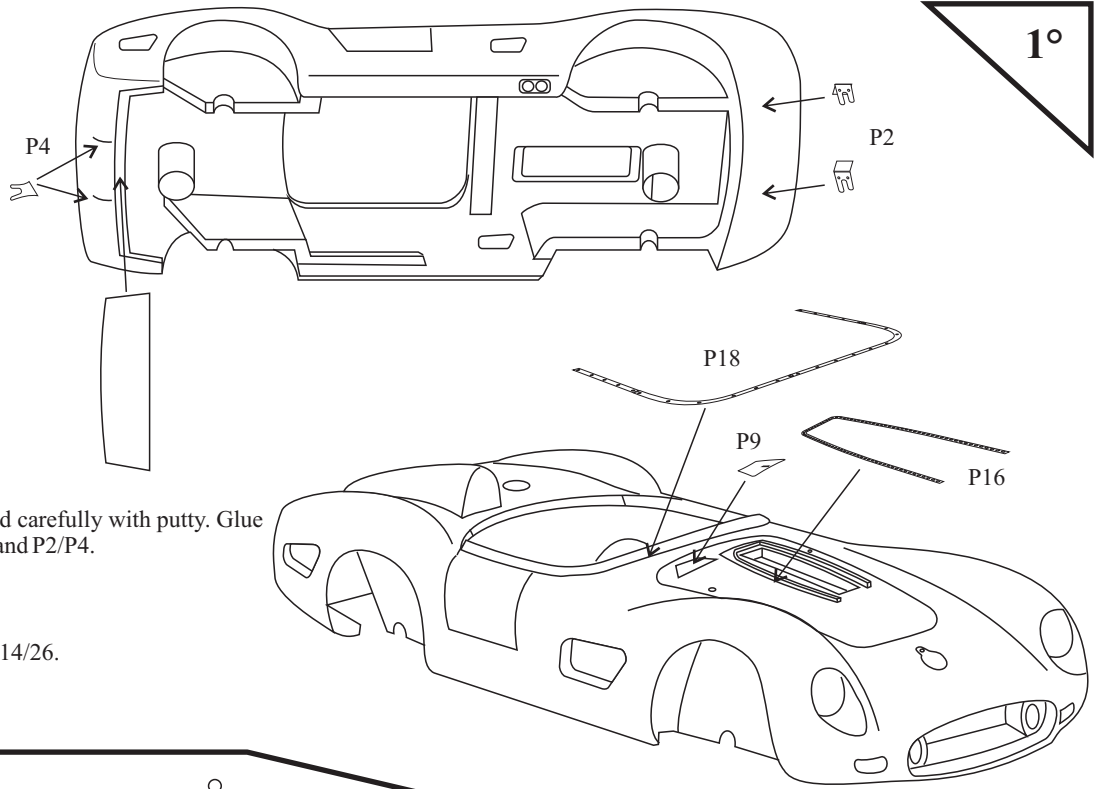

S4: Ajoutez un morceau de fil électrique pour la charnière.. Add thin wire as hinge...

4

Vissez le chassis sur la caisse
Screw chassis to body.

Rétro: Utilisez du fin fil électrique pour la tige...
Mirror: use thin electrical wire as a rod...

Pliez le tableau de bord à l'aide d'une tige, pour conserver un arrondi...
Fold P19 dashboard using a rod, to get it round on folding line ..

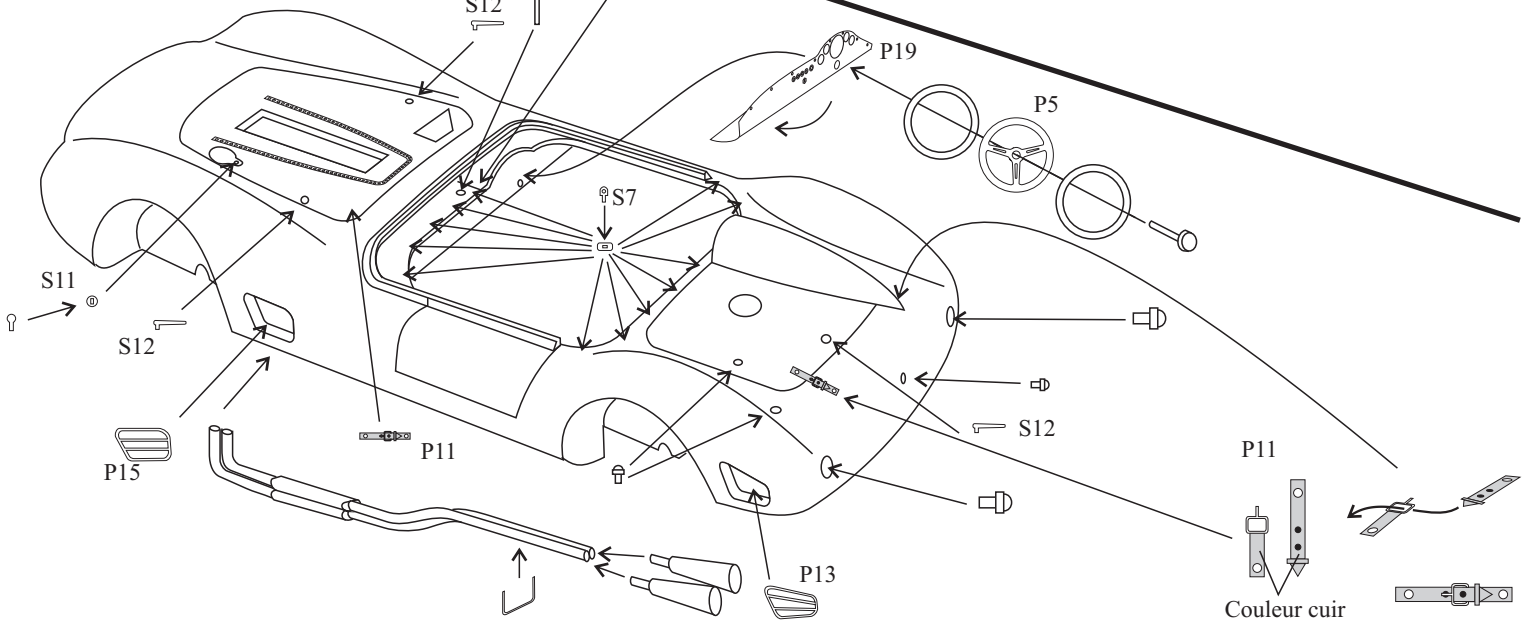

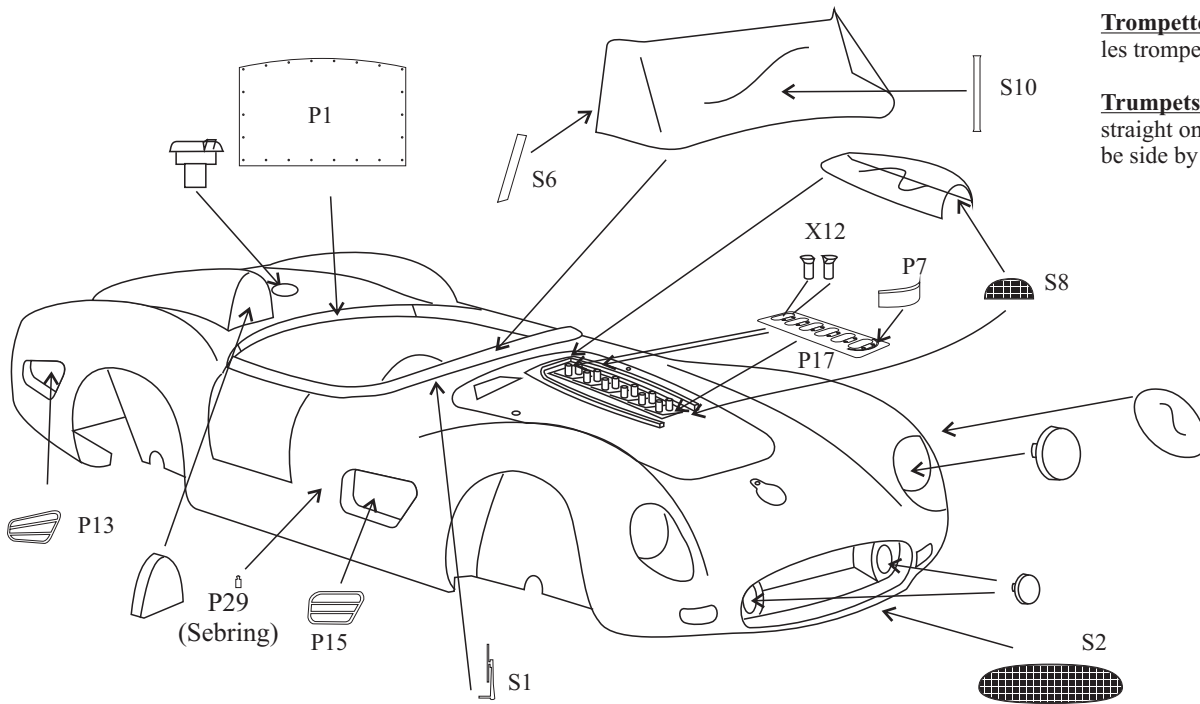

Trompettes: Limez un flanc d'ouverture, les trompettes sont accolées l'une à l'autre.

Trumpets: using a needle file, make a straight on operture, the trumpets have to be side by side.

Vitrages:

Découpez largement les thermoformages, vérifiez leur positionnement et finissez l'ajustage à la lime. Collez à l'aide d'une colle blanche (MicroScale Liqui Tape)

Windows:

Cut "largely" the vacformed parts, verify location then finish to adjust using a needle file. Use a clear glue like MicroScale LiquiTape.

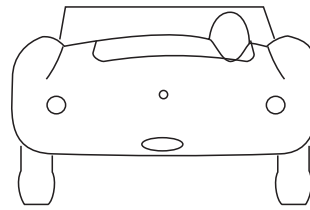
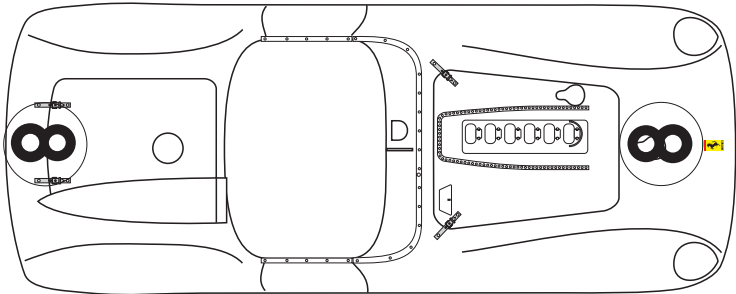

n°8: Hill-Gendebien
sur 0770
Sebring 1959

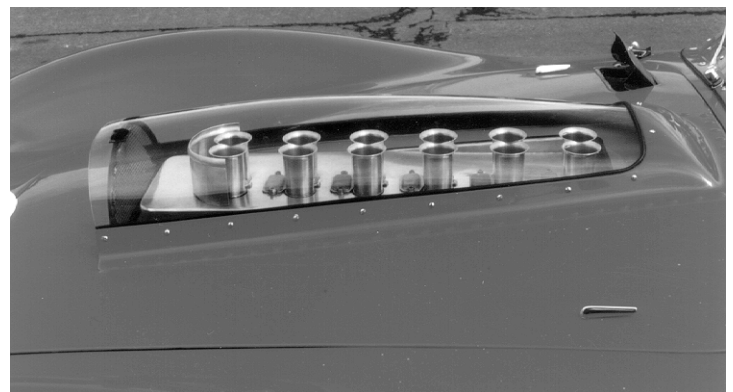
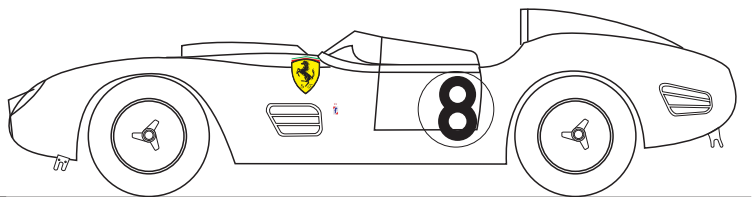
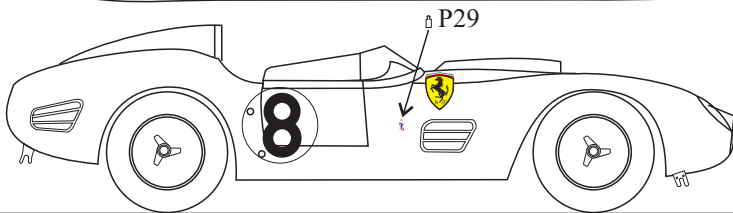

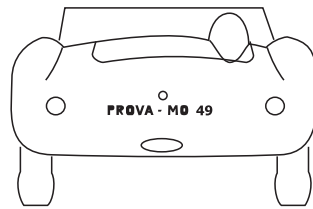
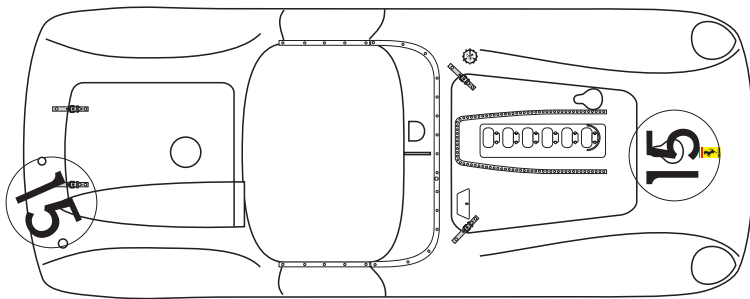

N°15:
Allison-da Silva Ramos
sur 0770 aux 24 Heures
du Mans 1959

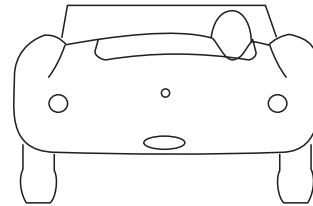
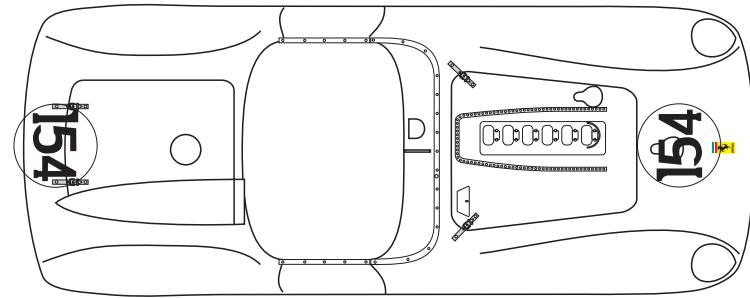
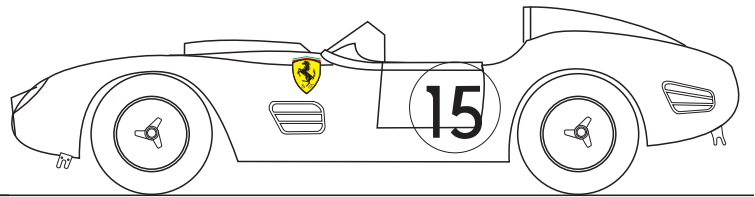
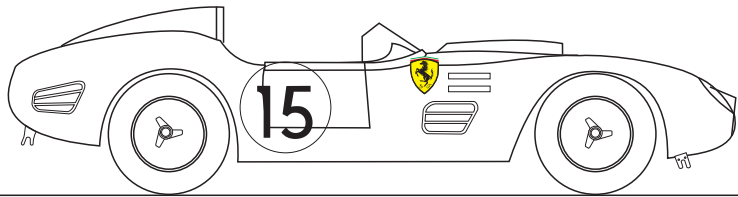

N°154: Gurney-Allison
sur 0770,
dnf Targa Florio 1959

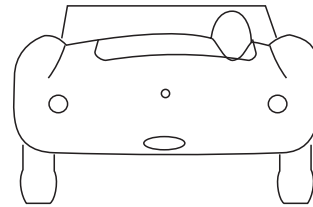
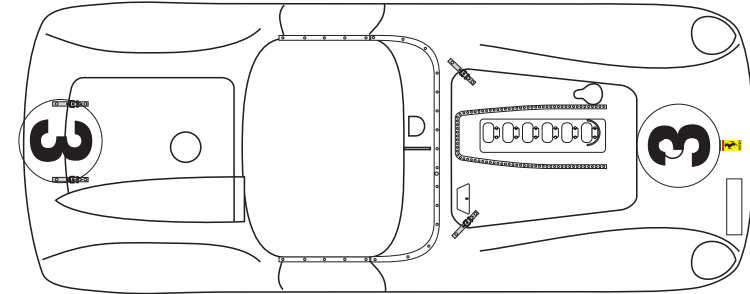
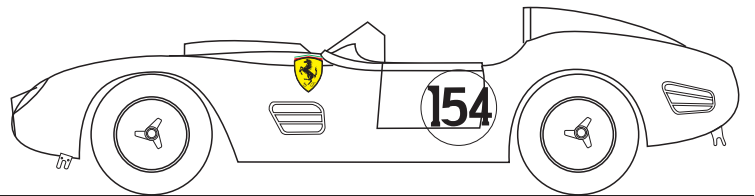
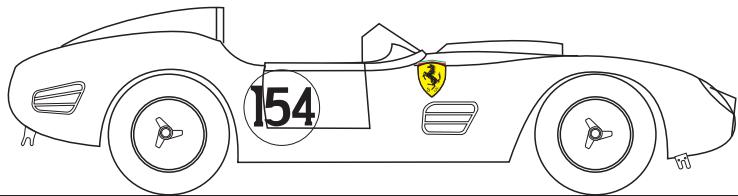

N°3: Behra-Brooks
sur 0768 (?),
3e Nürburgring 1959

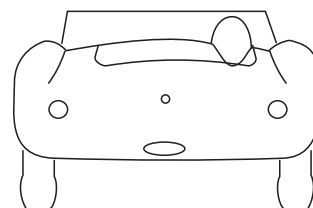
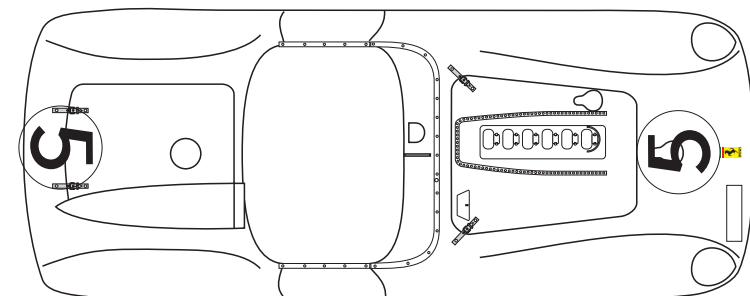
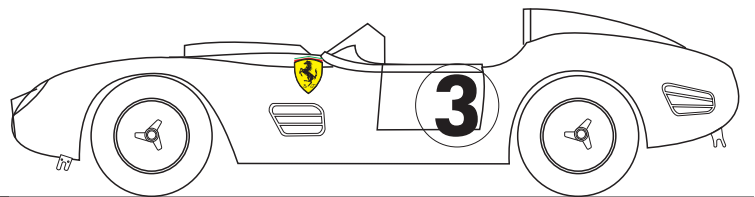
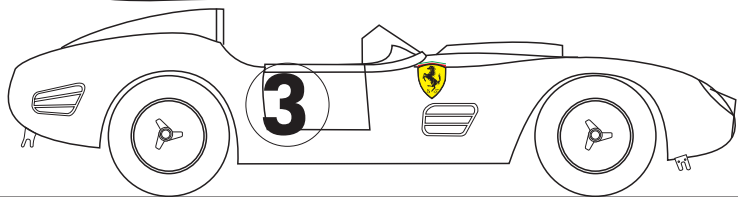

N°5: Gurney-Allison
sur 0770, 5es au
Nürburgring 1959

